

# Elastomer Jaw Couplings

## RINGFEDER® TNM E

One-part design with 2 identical coupling hubs

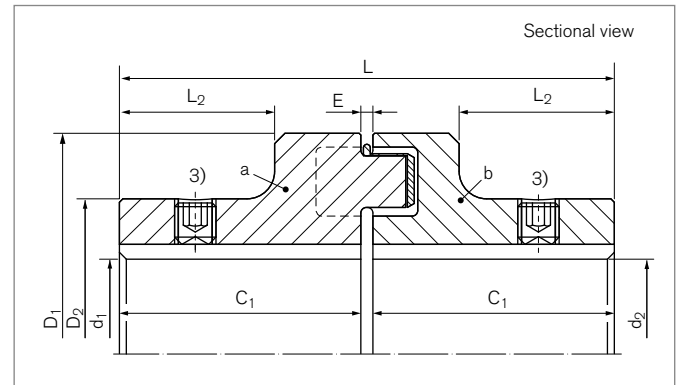

Identifier	Size	$T_{KNPb72}^{2)}$	$T_{KNPb82}^{2)}$	$n_{max}$	$d_{1kmax}$	$d_{2kmax}$	$D_1$	$D_2$
		Nm	Nm	1/min	mm	mm	mm	mm
WN0105	50	13	20	5000	19	19	50	33
WN0106	67	22	35	5000	28	28	67	46
WN0108	82	48	75	5000	32	32	82	53
WN0109	97	96	150	5000	42	42	97	69
WN0111	112	150	230	5000	48	48	112	79
WN0112	128	250	380	5000	55	55	128	90
WN0114	148	390	600	4500	65	65	148	107
WN0116	168	630	980	4000	75	75	168	124
WN0119	194	1050	1650	3500	85	85	194	140
WN0121	214	1500	2400	3000	95	95	214	157
WN0124	240	2400	3700	2750	110	110	240	179
WN0126	265	3700	5800	2500	120	120	265	198
WN0129	295	4900	7550	2250	130	130	295	214
WN0133	330	6400	9900	2000	150	150	330	248
WN0137	370	8900	14000	1750	170	170	370	278
WN0141	415	13200	20500	1500	190	190	415	315
WN0148	480	18000	28000	1400	210	210	480	315
WN0157	575	27000	41000	1200	230	230	575	350

To continue see next page

## Elastomer Jaw Couplings RINGFEDER® TNM E

Identifier	Size	C <sub>1</sub>	L	L <sub>2</sub>	E	F <sub>E</sub>	G <sub>wa</sub> <sup>1)</sup>	G <sub>wub</sub>
		mm	mm	mm	mm	mm	kg	kg
WN0105	50	25	52	13	2	+/- 0,5	0,2	0,4
WN0106	67	30	62,5	15	2,5	+/- 0,5	0,5	1,0
WN0108	82	40	83	24	3	+/- 1,0	0,9	1,8
WN0109	97	50	103	30	3	+/- 1,0	1,7	3,4
WN0111	112	60	123,5	38	3,5	+/- 1,0	2,6	5,3
WN0112	128	70	143,5	45	3,5	+/- 1,0	4,1	8,2
WN0114	148	80	163,5	52	3,5	+/- 1,0	6,3	12,7
WN0116	168	90	183,5	56	3,5	+/- 1,5	9,6	19,3
WN0119	194	100	203,5	62	3,5	+/- 1,5	13,8	27,9
WN0121	214	110	224	68	4	+/- 2,0	19,1	38,2
WN0124	240	120	244	75	4	+/- 2,0	26,7	53,4
WN0126	265	140	285,5	90	5,5	+/- 2,5	37,5	75,0
WN0129	295	150	308	98	8	+/- 2,5	47,9	95,7
WN0133	330	160	328	104	8	+/- 2,5	66,5	132,9
WN0137	370	180	368	118	8	+/- 2,5	93,9	187,7
WN0141	415	200	408	135	8	+/- 2,5	129,7	259,3
WN0148	480	220	448	150	8	+/- 2,5	164,4	328,7
WN0157	575	240	488	170	8	+/- 2,5	233,5	467,0

<sup>1)</sup> Weight inclusive the half share of the intermediate ring

<sup>2)</sup> Attention on peak load – see chapter „RINGFEDER® TNM Basic information“ in Product Paper & Tech Paper „RINGFEDER® Elastomer Jaw Couplings“

<sup>3)</sup> Set screw on demand

### Explanation

<b>T<sub>KNPb72</sub></b> = Coupling nominal torque by using the elastic element Pb72	<b>d<sub>2kmax</sub></b> = Max. bore diameter d <sub>2</sub> with keyway acc. to DIN 6885-1	<b>E</b> = Gap width between left and right component
<b>T<sub>KNPb82</sub></b> = Coupling nominal torque by using the elastic element Pb82	<b>D<sub>1</sub></b> = Outer diameter	<b>F<sub>E</sub></b> = Tolerance of the gap width E
<b>n<sub>max</sub></b> = Max. rotation speed	<b>D<sub>2</sub></b> = Outer diameter hub	<b>G<sub>wa</sub></b> = Weight of subassembly a
<b>d<sub>1kmax</sub></b> = Max. bore diameter d <sub>1</sub> with keyway acc. to DIN 6885-1	<b>C<sub>1</sub></b> = Guided length in hub bore	<b>G<sub>wub</sub></b> = Weight, unbored
	<b>L</b> = Total length	
	<b>L<sub>2</sub></b> = Length on the hub	

### Ordering example

Identifier	Size	d <sub>1k</sub>	d <sub>2k</sub>	Buffer identifier (optional) <sup>4)</sup>	Further details
WN0157	575	200	220	Pb82	*

<sup>4)</sup> Details on elastomer materials see chapter „Introduction“ and „RINGFEDER® TNM Basic information“ in Product Paper & Tech Paper „RINGFEDER® Elastomer Jaw Couplings“

<sup>5)</sup> Without any other specification, we deliver as a standard: with set screws and keyway acc. to DIN 6885-1, keyway side fit P9, bore tolerance H7

Further information on  
**RINGFEDER® TNM E**  
 on [www.ringfeder.com](http://www.ringfeder.com)

#### Disclaimer of liability

All technical details and notes are non-binding and cannot be used as a basis for legal claims. The user is obligated to determine whether the represented products meet his requirements. We reserve the right carry out modifications at any time in the interests of technical progress.